

AODD PUMPS FOR YOUR MOST SEVERE APPLICATIONS

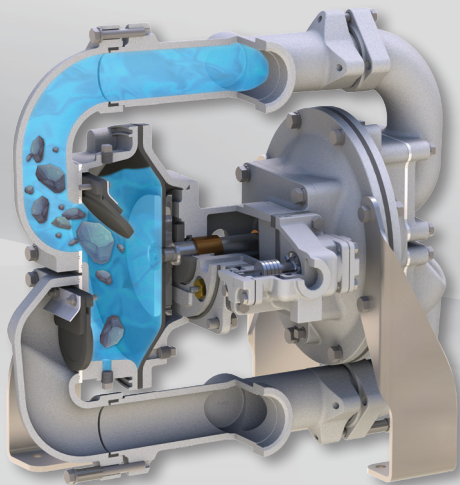

**HEAVY DUTY
FLAP VALVE PUMP**

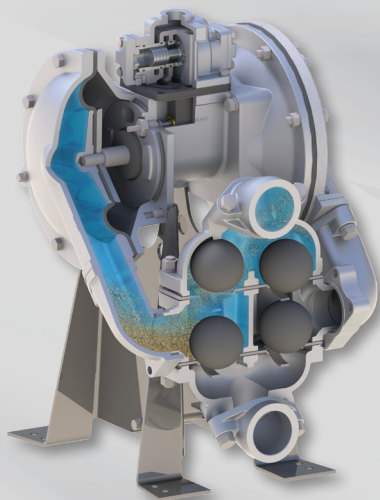

**HEAVY DUTY
BALL VALVE PUMP**

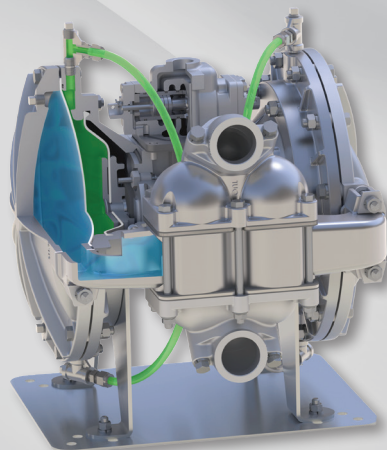

**CONTAINMENT DUTY
BALL VALVE PUMP**



OUR SIGNATURE
ENSURES YOUR
SUCCESS

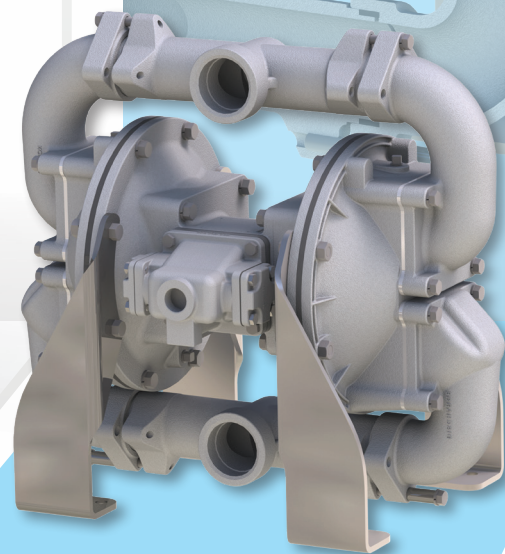
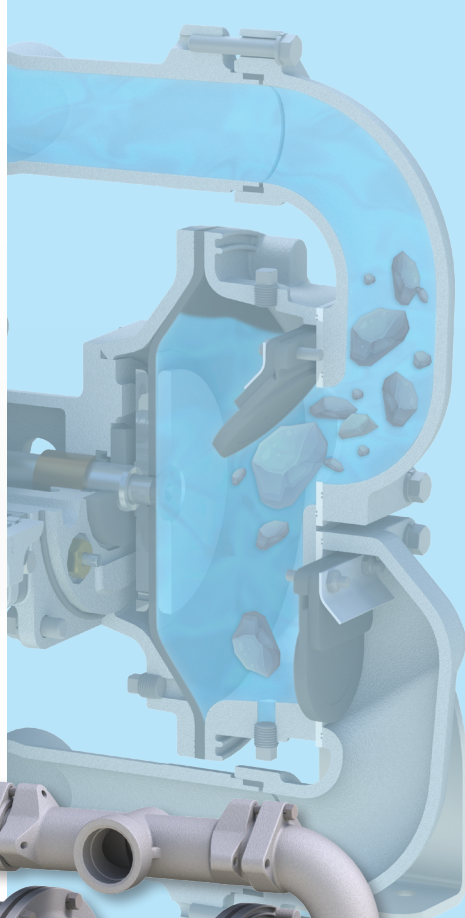

Heavy Duty Flap Valve

For fluids containing
up to line size solids.

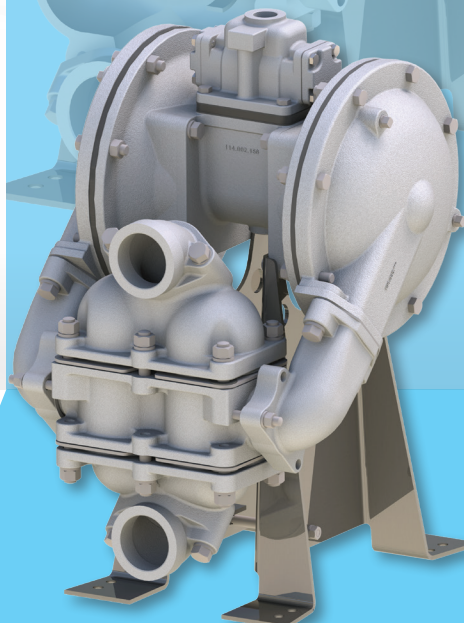
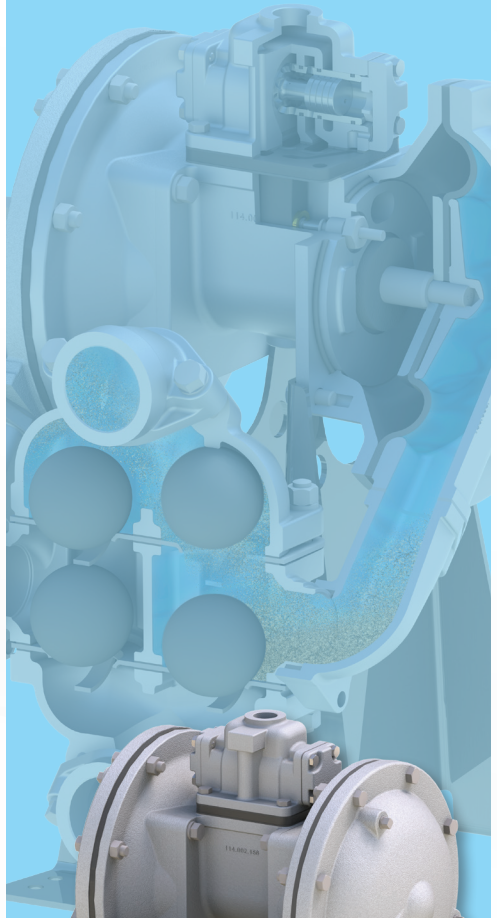

Heavy Duty Ball Valve

For fluids containing settling,
suspended & floating solids.

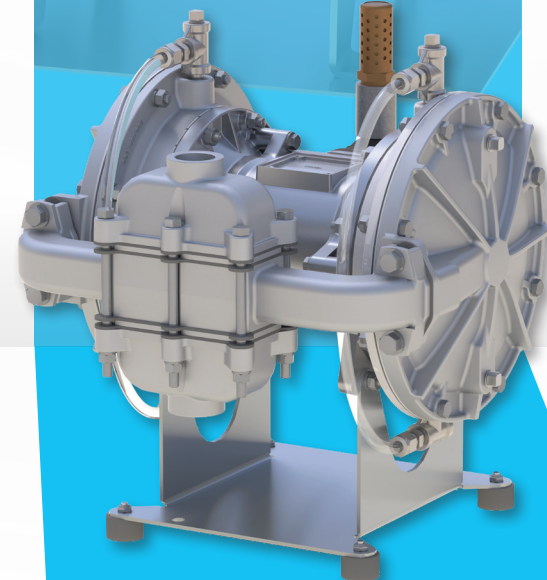
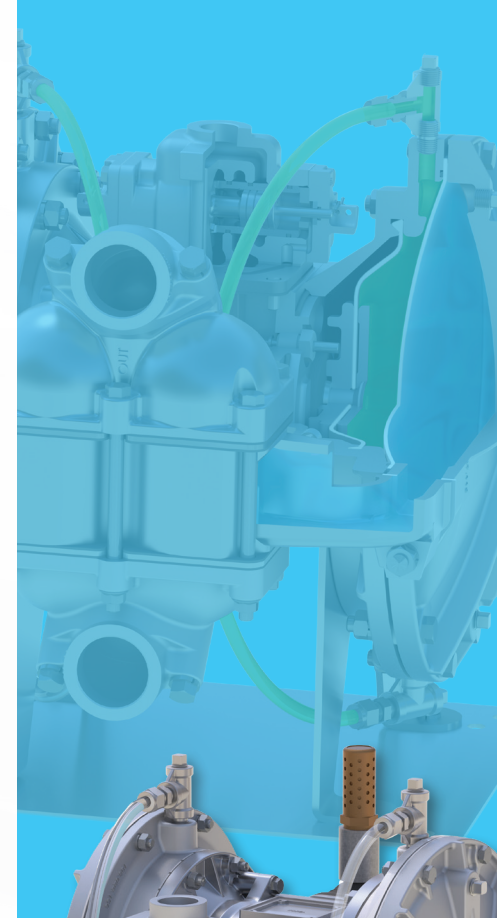

Containment Duty Ball Valve

The only complete line of AODD
pumps featuring superior fluid
containment; protecting your
people, environment and pump.

SANDPIPER Signature Series™ AODD pumps are engineered to deliver industry leading durability and performance, even for your most severe applications and environments.



**ROBUST DIAPHRAGM
CONNECTING ROD**
Guaranteed not to yield under
tension, compression, or bending



**5 YEAR LIMITED
PRODUCT WARRANTY**
5 Year Guarantee for defects
in material or workmanship

LEARN MORE AT: SANDPIPERPUMP.COM/SIGNATURE-SERIES

HEAVY DUTY FLAP VALVE PUMPS

FOR FLUIDS CONTAINING UP TO LINE SIZE SOLIDS



OUR SIGNATURE ENSURES YOUR SUCCESS
Industry leading durability and performance for your most severe applications

TECH SPECS:

SIZES: 1 - 4" (25 - 102 mm) **FLOW:** 70 - 310 GPM (265 - 1173 LPM)

SOLIDS HANDLING: 1 - 3" (25 - 76 mm) **DISPLACEMENT:** .1 - 1.6 gallons (.38 - 6.06 liters)

CONSTRUCTION: Aluminum, Cast Iron, Stainless Steel, Polypropylene

ELASTOMERS: (Diaphragms & Flaps) Nitrile, Neoprene, Hytre[®], Santoprene[®], Fluorocarbon, EPDM, Urethane

PUMPS UP TO LINE SIZE SOLIDS

Flap Valve construction has a larger flow area than Ball Valve pumps and allows up to line size solids to pass directly through the pump.

BOTTOM DISCHARGE PORTING

Allows settling solids to pass through the pump and not settle inside the pumping chamber, preventing damage and premature wear.

SUPERIOR SUCTION LIFT

Dry prime suction lift up to 24 feet, in water; which is 5% greater than typical Ball Valve pumps.

EASIEST AODD PUMP TO MAINTAIN

Quick access to serviceable components to help increase productivity and reduce downtime.

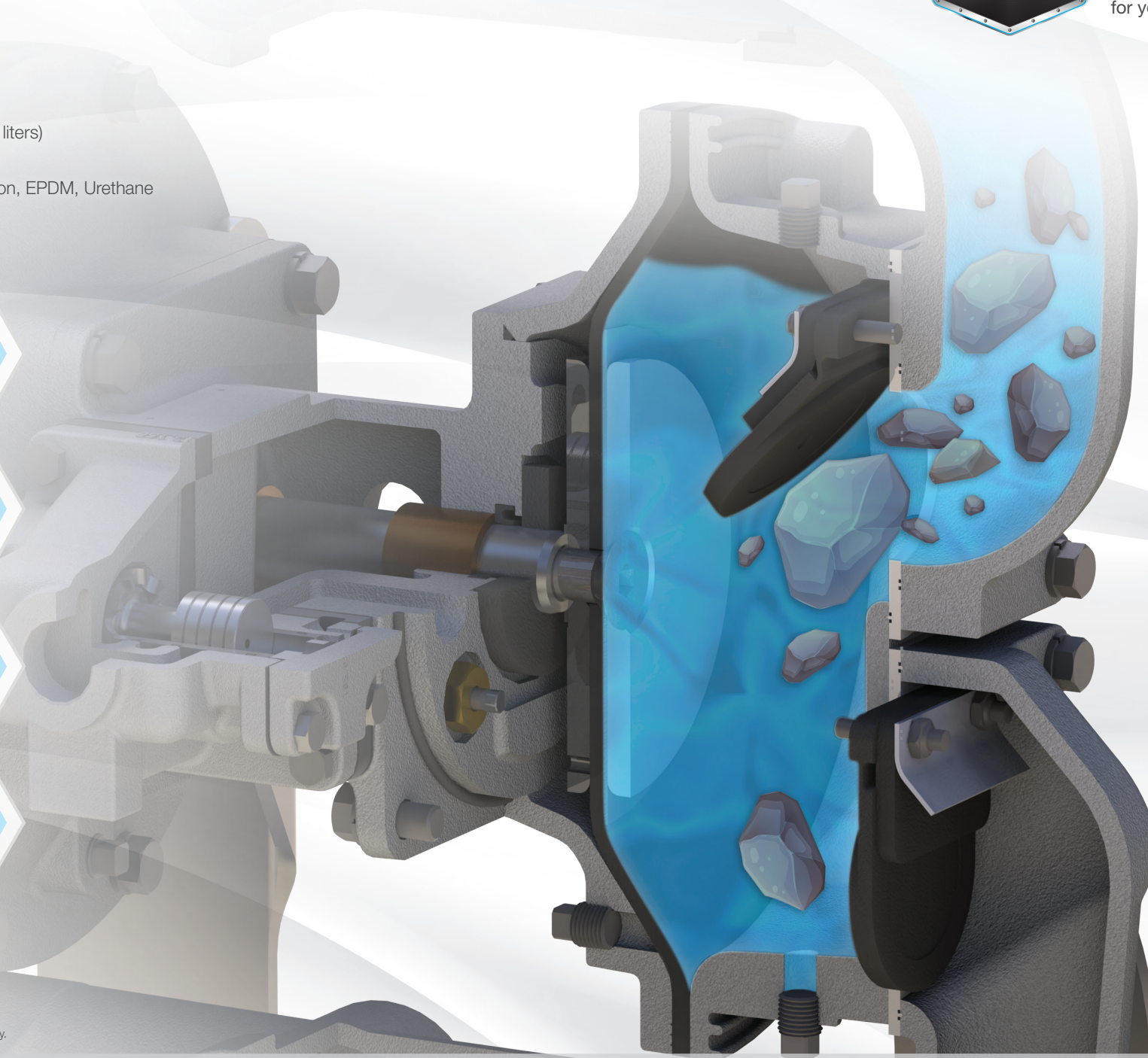

APPLICATIONS			
FLUID CHARACTERISTICS	Water	✓	
	Suspended Solids	✓	
	Non-Suspended Solids	✓	
	Line Size Solids	✓	
	Sludge/Slurry	✓	
	High Viscosity (Flowable Fluids)	✓	
	Erosion/Abrasive Fluids	High	✓
		Mod.	✓
		Low	✓
	Corrosion	✓	
INSTALLATION	Permanent	✓	
	Portable	✓	
	Containment/Prevention	!	
	Flooded Suction	✓	
	Suction Lift	✓	
	Submerged	✓	
DUTY	Intermittent/On-Demand	✓	
	Continuous	✓	

✓ = Best ✓ = Suited ! = Limitations
⚠ = Use listed pump

Santoprene[®] is a registered tradename of Exxon Mobil Corp. Hytre[®] is a registered trademark of E.I. du Pont de Nemours and Company.



Diaphragm Wear Pads

Extend diaphragm life by reducing the frictional stresses associated with the outer diaphragm plate



Thick Manifold and Chamber Walls

Greater wear resistance when pumping solids and solid laden slurries, providing extended service life



ESADS+Plus Air Distribution System

Allows for quick and easy access to the main air valve components without removing it from service



All Bolted Construction

Ensures sealing forces are applied evenly across the pump for leak-free operation



Robust Diaphragm Connecting Rod

Guaranteed not to bend or break; assures reliable and consistent diaphragm operation



Cross-Drilled Directional Spool Valve

Guarantees the pump will not stall and ensures on / off reliability



Heavy Duty Actuator Plungers

Ensures reliable pilot valve operation



Stainless Steel Check Valve Seats

Provide long-lasting abrasion resistance and solids handling durability

HEAVY DUTY BALL VALVE PUMPS

FOR FLUIDS CONTAINING SETTLING, SUSPENDED & FLOATING SOLIDS



OUR SIGNATURE ENSURES YOUR SUCCESS
Industry leading durability and performance for your most severe applications

TECH SPECS:

SIZES: 1 - 4" (25 - 102 mm) **FLOW:** 42 - 300 GPM (159 - 1136 LPM)

SOLIDS HANDLING: .25 - .875" (6 - 22 mm) **DISPLACEMENT:** .9 - 2.0 gallons (.34 - 7.6 liters)

CONSTRUCTION: Aluminum, Cast Iron, Stainless Steel, Alloy C

ELASTOMERS: (Diaphragms, Check Balls, Seats) Nitrile, Neoprene, Santoprene®, PTFE, Fluorocarbon, Hytrel®, EPDM

DOWN PORTED OPTION

For fluids containing settling solids. Solids collect in the elbow instead of the diaphragm chamber and are discharged, limiting wear on the diaphragm and components.

TOP PORTED OPTION

For fluids containing floating solids, suspended solids, or entrained gases. Discharge port is on top of the pump for easier evacuation and less build-up of solid material or gases.

SIDE PORTED OPTION (1" & 1-1/2" ONLY)

For use in confined spaces. The ports are positioned with the center of the pump, allowing for installation in small or confined spaces.

WEIGHTED CHECK VALVE BALLS

Feature a metallic core that is 30-60% heavier than a solid rubber check ball, helping to improve performance with viscous fluids.

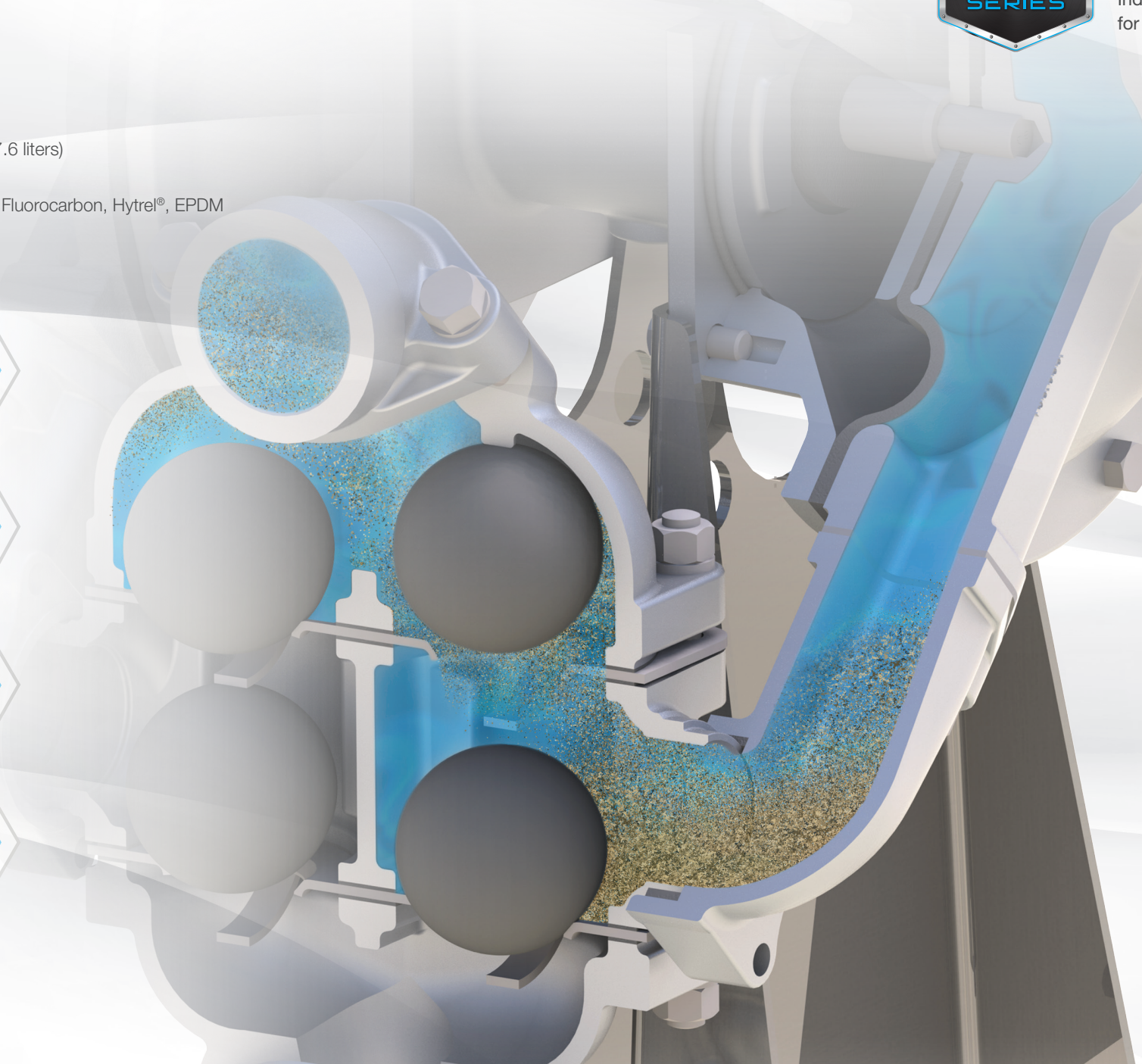

APPLICATIONS			
FLUID CHARACTERISTICS	Water	✓	
	Suspended Solids	✓	
	Non-Suspended Solids	✓	
	Line Size Solids	⚠ HD FLAP	
	Sludge/Slurry	✓	
	High Viscosity (Flowable Fluids)	✓	
	Erosion/Abrasive Fluids	High	✓
		Mod.	✓
		Low	✓
	Corrosion	✓	
INSTALLATION	Permanent	✓	
	Portable	✓	
	Containment/Prevention	!	
	Flooded Suction	✓	
	Suction Lift	✓	
	Submerged	✓	
DUTY	Intermittent/On-Demand	✓	
	Continuous	✓	

✓ = Best ✓ = Suited ! = Limitations
⚠ = Use listed pump

HDBALL



Diaphragm Wear Pads
Extend diaphragm life by reducing the frictional stresses associated with the outer diaphragm plate

ESADS+Plus Air Distribution System
Allows for quick and easy access to the main air valve components without removing it from service

Robust Diaphragm Connecting Rod
Guaranteed not to bend or break; assures reliable and consistent diaphragm operation

Heavy Duty Actuator Plungers
Ensures reliable pilot valve operation

Thick Manifold and Chamber Walls
Greater wear resistance when pumping solids and solid laden slurries, providing extended service life

All Bolted Construction
Ensures sealing forces are applied evenly across the pump for leak-free operation

Cross-Drilled Directional Spool Valve
Guarantees the pump will not stall and ensures on / off reliability

Large Flow Area
Reduces fluid velocity through pump, which often lessens wear

CONTAINMENT DUTY BALL VALVE PUMPS

THE ONLY COMPLETE LINE OF AODD PUMPS FEATURING SUPERIOR FLUID CONTAINMENT; PROTECTING YOUR PEOPLE, ENVIRONMENT & PUMP



OUR SIGNATURE ENSURES YOUR SUCCESS
Industry leading durability and performance for your most severe applications

TECH SPECS:

SIZES: 1 - 3" (25 - 76 mm) **FLOW:** 42 - 238 GPM (159 - 901 LPM)

SOLIDS HANDLING: .25 - .71" (6 - 18 mm) **DISPLACEMENT:** .09 - .9 gallon (.34 - 3.4 liters)

CONSTRUCTION: Aluminum, Cast Iron, Polypropylene, PVDF

ELASTOMERS: (Diaphragms, Check Valves, Seats) PTFE, Neoprene, Fluorocarbon, Santoprene®

NO LOST SYSTEM FLUID

Perfect for pumping fluids that are dangerous to your people or the environment. Makes repairs easy, as the Air Side of the pump does not get contaminated.

NO COSTLY CLEANUP

When a typical AODD pump has a diaphragm breach, the system fluid passes through the Air Side of the pump and out into the environment. Clean-up is expensive and time consuming.

2 DIAPHRAGMS ARE BETTER THAN 1

Features two diaphragms. The space between the diaphragms creates a barrier between the Air Side and Wet Side of the pump, preventing escape of the fluid to the environment when the pumping diaphragm becomes breached.

VISUAL LEAK DETECTION

Alerts the user when there is a diaphragm breach before any of the system fluid can escape to the environment. Also available with electronic and mechanical leak detectors.

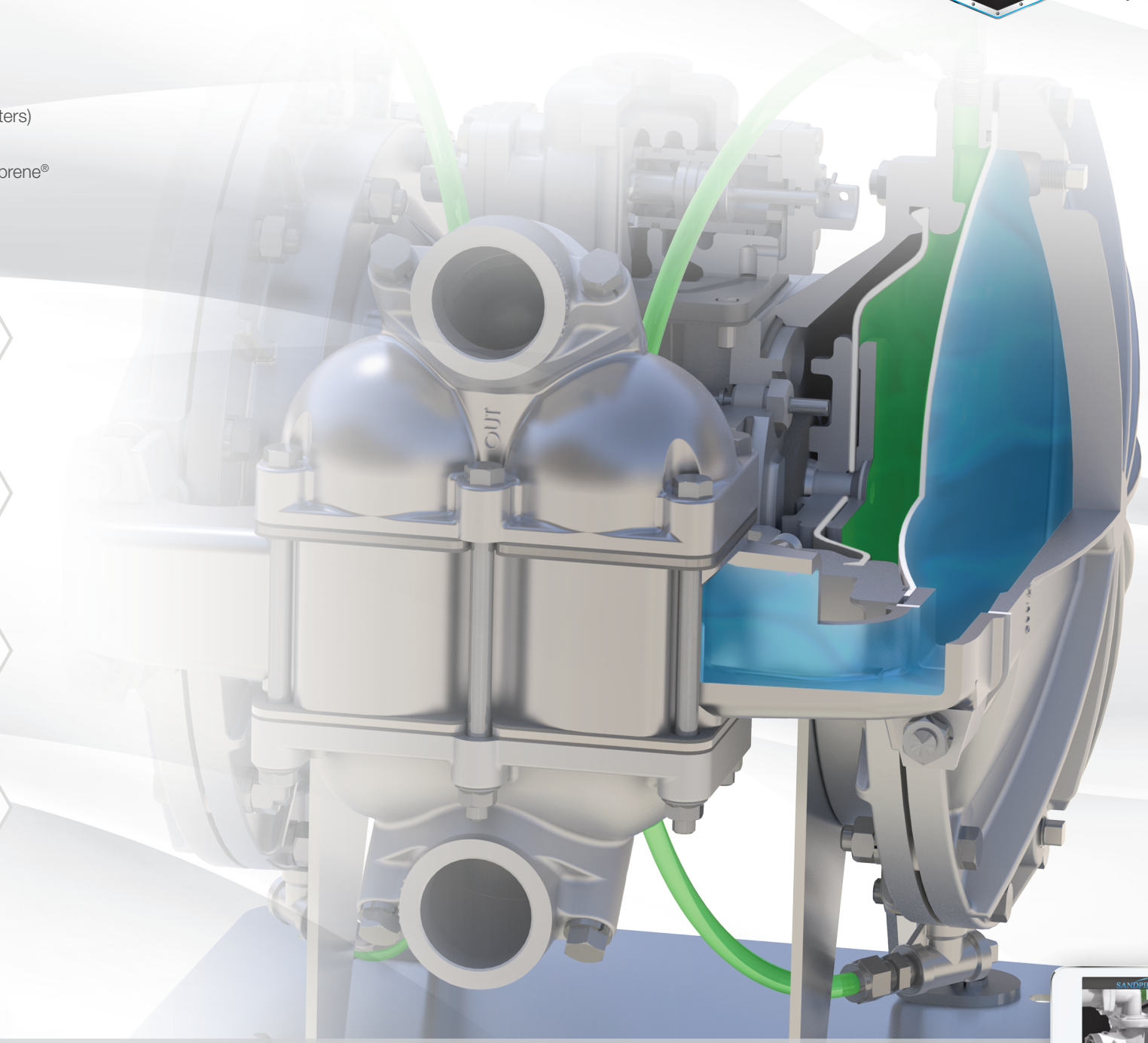

APPLICATIONS			
FLUID CHARACTERISTICS	Water	✓	
	Suspended Solids	✓	
	Non-Suspended Solids	⚠ NOT RECOMMENDED	
	Line Size Solids	⚠ NOT RECOMMENDED	
	Sludge/Slurry	!	
	High Viscosity (Flowable Fluids)	✓	
	Erosion/Abrasive Fluids	High	!
		Mod.	!
		Low	✓
	Corrosion	✓	
INSTALLATION	Permanent	✓	
	Portable	✓	
	Containment/Prevention	✓	
	Flooded Suction	✓	
	Suction Lift	✓	
	Submerged	!	
DUTY	Intermittent/On-Demand	✓	
	Continuous	✓	

✓ = Best ✓ = Suited ! = Limitations
⚠ = Use listed pump



CDBALL



Pumping Diaphragm

Stays in contact with the fluid and moves it through the system



Driver Diaphragm

Stays in contact with the Air Side of the pump and is hydraulically locked to the Pumping Diaphragm



Containment Chamber

Area between the two diaphragms, creating a barrier between the Air Side and Wet Side



ESADS+Plus Air Distribution System

Allows for quick and easy access to the main air valve components without removing it from service



Robust Diaphragm Connecting Rod

Guaranteed not to bend or break; assures reliable and consistent diaphragm operation



Cross-Drilled Directional Spool Valve

Guarantees the pump will not stall and ensures on / off reliability



WATCH THE VIDEO TO LEARN MORE:
SANDPIPERPUMP.COM/CONTAINMENT

ARE YOU USING THE CORRECT PUMP?

SANDPIPER SIGNATURE SERIES™ - THE ONLY AODD PUMPS DESIGNED TO OPERATE UNDER THE MOST SEVERE CONDITIONS

NUTS, BOLTS, & SCREWS

ROCKS, TWIGS, & LEAVES

RAGS

HEAVY DUTY FLAP

FLOATING SOLIDS

PEA GRAVEL

SAND & SLURRIES

HEAVY DUTY BALL

CORROSIVE FLUIDS

PAIN

TOXIC FLUIDS

CONTAINMENT DUTY



SANDPIPER SIGNATURE SERIES™: DESIGNED TO PROVIDE SUPERIOR PERFORMANCE WHERE OTHER AODD PUMPS FAIL

- Industrial Sumps
- Filter Press
- Wastewater
- Paints
- Food
- Animal Fats
- Asphalt Sealant
- Mine Dewatering
- Slurries
- Pulp
- Glues
- Chemicals
- Varnish
- Fertilizers
- Mud Transfer
- Rendering
- Ceramic Slip
- Resins
- Hydrocarbons
- Latex Lotions
- Beer & Alcohol

SANDPIPER VS COMPETITION

HEAVY DUTY FLAP VALVE PUMP

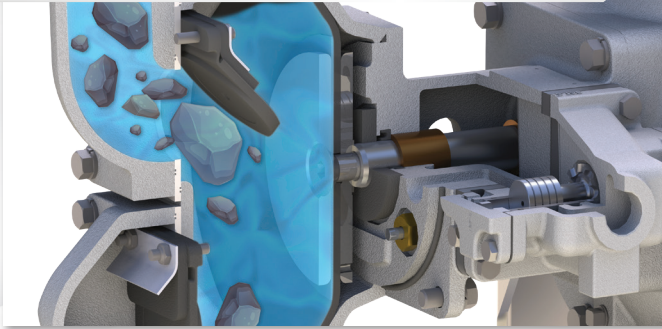

Large solids easily pass through pump

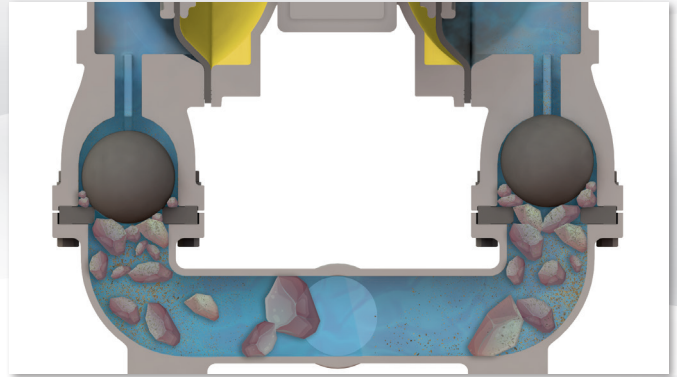

Large solids cannot pass through pump, affecting operation

HEAVY DUTY BALL VALVE PUMP

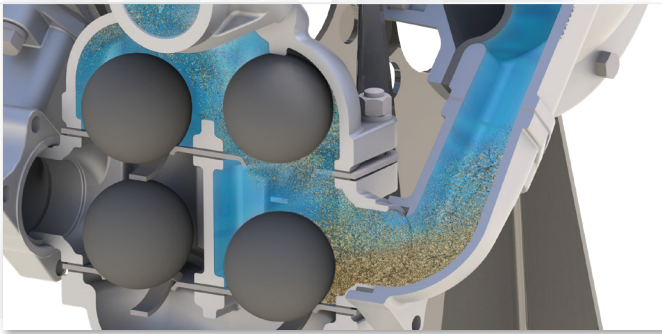

Settling solids easily pass through pump

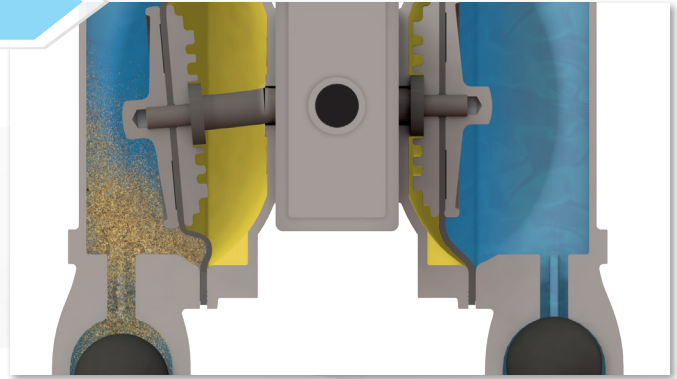

Settling solids collect inside pump, causing damage & affecting operation

CONTAINMENT DUTY BALL VALVE PUMP

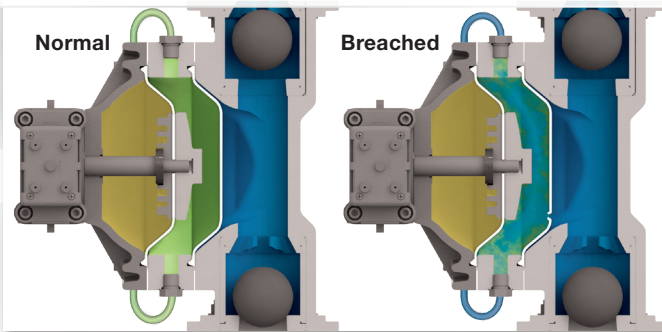

Contains fluid when diaphragm becomes breached

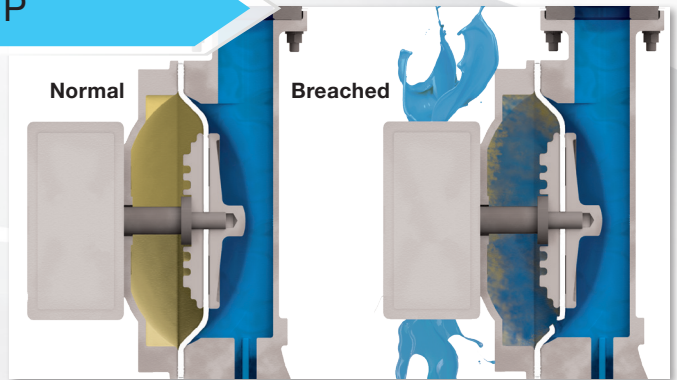

Fluid escapes to environment when diaphragm becomes breached.

[Contact Your Local Distributor to Place Your Order:](#)

SANDPIPER[®]

Warren Rupp, Inc. | A Unit of IDEX Corporation
800 North Main Street, Mansfield, OH 44902 USA
Phone: 419.524.8388 | Fax: 419.522.7867
SANDPIPERPUMP.COM



IDEX